

Evaluating Thermal Performance of Solar Cookers under Jordanian Climate

M. Abu-Khader^a, M. Abu Hilal^b, S. Abdallah^{c*}, and O. Badran^a

^a Department of Chemical Engineering, FET, Al-Balqa Applied University, Amman, Jordan

^b Department of Mechanical Engineering, An-Najah National University, Nablus, Palestine

^c Applied Science University, Mechanical and Industrial Engineering Department, Amman, Jordan

Abstract

This study presented a short review on the solar cooker designs and applications. Two designs of cookers were tested. The first type has a painted black base and second has internal reflecting mirrors. These designs were examined under two modes of operations: at fixed position and on tracking system. The cooker at a fixed position had recorded thermal efficiencies ranging from 17 % to a sharp peak of 41.2% at the maximum solar intensity of the day around 11-12 am with an average overall efficiency around 27.6%. Whereas, cooker with internal reflecting mirrors installed on a sun tracking system gave higher water and pot temperatures, and thermal efficiency ranged from 25.3% to 53.1% with an average overall efficiency around 40.6 %. Cookers installed on sun tracking system had the advantage of maintaining a higher and closer range of thermal efficiencies through the daylight than the ones at fixed positions.

© 2011 Jordan Journal of Mechanical and Industrial Engineering. All rights reserved

Keywords: Seat belt, smart restraint systems, fuzzy logic.

1. Introduction

Due to the high increase in the prices of fuel and energy, the search for alternative cheaper source of energy is of necessity. Therefore, solar energy is becoming a viable option. Solar cookers are rather important applications in thermal solar energy conversion. The use of solar cooker for cooking purposes is spreading widely in most developing countries and in particular in villages and remote areas. The solar cooker must be high quality, affordable, user friendly, light weight, stackable and a family size. Current designs of solar cookers normally used are box cookers, concentrators, and flat plate collector cookers.

The basic purpose of a solar box cooker is to heat things up - cook food, purify water, and sterilize instruments. A solar box cooks because the interior of the box is heated by the energy of the sun. Sunlight enters the solar box through the glass. It turns to heat energy when absorbed by the dark absorber plate and cooking pots. This heat input causes the temperature inside of the solar box cooker to rise until the heat loss of the cooker is equal to the solar heat gain. Temperatures sufficient for cooking food and pasteurizing water are easily achieved.

As the density and weight of the materials within the insulated shell of a solar box cooker increase, the capacity of the box to hold heat increases. The interior of a box including heavy materials such as rocks, bricks, heavy pans, water, or heavy foods will take longer to heat up because of this additional heat storage capacity. The incoming energy is stored as heat in these heavy materials and the air in the box.

The important parts of a hot box solar cooker include a) outer box: made of galvanized iron or aluminum sheet, b) inner cooking box: made from aluminum sheet and coated with black paint so as to easily absorb solar radiation and transfer the heat to the cooking pots, c) thermal insulator: The space between the outer and inner box is packed with insulating material such as glass wool pads to reduce heat losses from the cooker, d) mirror: used in a solar cooker to increase the radiation input on the absorbing space and fixed on the inner side of the main cover of the box. This radiation is in addition to the radiation entering the box directly and helps to quicken the cooking process by raising the inside temperature of the cooker, e) cooking containers: generally made of aluminum or stainless steel. These pots are also painted black on the outer surface so that they also absorb solar radiation directly.

The main objective of this present work is to investigate two designs of solar cookers. Figure 1 presents two designs of solar cookers under investigation. Also, evaluate the various parameters affecting cookers performance under different modes of operation such as at fixed position and moving on a tracking system. Experimental work and validation of mathematical modeling are carried out and compared. An overview and up to date literature will be presented.



Figure 1 Tested solar cookers: a) Black painted box type cooker, and b) Mirrors box type cooker

*Corresponding author: salahabdalah@asu.edu.jo

2. Solar Cookers: Review

Solar cookers are simple, cheap, trouble-free, with good efficiency. Solar cookers were used as early as 1776 by DeSaussure, who used a hot box-type oven. Telkes [1] and Burkhardt [2] presented one of the earliest reviews on solar cookers. From early design considerations on the development of an urban solar cooker goes back for more than 30 years [3-10]. There are several different designs for the hot box-type ovens which can be summarized as follows:

1. Simple plane hot box ovens where the food pot is enclosed inside the oven box. The oven is heated by direct solar radiation transmitted through its glass cover [11-15].
2. Booster plane reflectors can be used in conjunction with the hot box to increase the oven temperature to enhance its efficiency [14, 16]. Mannan et al. [17] described a solar oven with compound conical reflectors.
3. Indirect hot box ovens in which the cooker is heated indirectly by means of steam flowing through heat pipes which are enclosed in a plate collector, Whillier [18].
4. The Telkes oven is one of the most familiar configurations of hot box oven types [19- 20].

Several research works were conducted on the thermal testing and performance evaluation for concentrating solar cooker and combined concentrating/oven type solar cooker, and parameters that characterize the performance of the solar cooker [21- 24]. Evaluation of solar cooker thermal performance using different insulating material [25]. The hot box solar cooker was tested in an indoor solar simulator with covers consisting of 40 and 100 mm thick Transparent Insulation Material (TIM), [26]. The addition of a plane reflector to a box-type solar cooker increases the obtained cooker temperature and thermal performances [27]. A series of out-door experiments were performed on the double-glazed solar cooker [28].

A simple solar cooker of hot box type with a plane booster mirror reflector was designed and evaluated under Egyptian climate. The performance of the cooker was measured experimentally [29, 30]. In Brunei Darussalam, a program to develop, test and evaluate a solar cooker was carried out [31]. Whereas, In Turkey, a box-type solar cooker was designed and its thermal performance is analyzed experimentally. The cooker tracks the sun in two axes, altitude and sun azimuth, by hand control for hourly periods [32]. A cylindrical shaped box type solar cooker was constructed and its thermal performance was tested under the prevailing weather conditions in Karabuk, Turkey. Experiments were conducted on a single glazed cooker with a plane reflector and one cooking pot [33].

One of the earliest mathematical models to test the thermal performance of a Solar Cooker was presented by Garg et. al. [34], and Vaishya et al., [35]. Also, Jubran and Alsaad [36] presented theoretical model for a single and double, glazed box-type solar cookers with or without reflectors. Whereas, Das et. al [37, 38] and Binark and Turkmen [39] developed thermal models for the solar box-cookers loaded with one, two, or four vessels. On the other hand, Funk and Larson [40] presented a model for

prediction of the cooking power of a solar cooker based on three controlled parameters (solar intercept area, overall heat loss coefficient, and absorber plate thermal conductivity) and three uncontrolled variables (insulation, temperature difference, and load distribution). A simple mathematical model is presented for a box-type solar cooker with outer-inner reflectors [41]. Ozkaymak [42] developed a mathematical model for a box- type solar cooker with three reflectors hinged at the top of the cooker. Energy-balance equations were applied to components of the cooker such as absorber plate, cooking vessel, cooking fluid, enclosure air inside the cooker, and glass cover.

For transient mathematical models, Yadav and Tiwari [43] presented transient analytical study of box type solar cookers. Elsebaai, et. al [44] designed and constructed a box-type solar cooker with multi-step inner reflectors. The inner reflectors were arranged in a three-step fashion to create different angles with respect to the horizontal. A transient mathematical model is presented for the cooker. Also, Elsebaai and Aboulenein [45] developed such a model for a box-type solar cooker with a one step outer reflector hinged at the top of the cooker.

A novel solar cooker that does not require any tracking, has been designed, fabricated and tested and its performance has been compared with the hot-box solar cooker. The performance of the novel solar cooker is almost similar with the hot-box solar cooker though it is kept fixed while the hot box is tracked towards the sun every hour. The overall efficiency of the novel solar cooker has been found to be 29.5%. [46]. A double reflector hot box solar cooker with a Transparent Insulation Material has been designed, fabricated, tested and the performance compared with a single reflector hot box solar cooker without TIM [47].

3. Experimental System Set-up

The experimental tests on the solar cookers were carried out during the successive days from the 29th and 31st /10/2007 and 2nd /11/ 2007. Each experiment starts from 7:30 am in the morning to 16:00 pm in the afternoon. The electrical and electronic parts were tested and calibrated before being used on the various designs on both solar cookers. The experimental work was fully carried out in the Renewable Energy laboratory at the Applied Science University, Amman-Jordan.

The first part of this research work concentrated on testing of two box type cookers: traditional black painted cooker and internal installed mirrors cooker as shown in Figure 1. Both cookers are fixed at a position towards the south. The second part is testing the traditional black painted cooker with a tracking system to the sun movement. Figure 2 shows schematic diagram of three dimension of the solar cooker installed on a horizontal sun tracking system. It shows the base, motor and bearing and sun cooker.

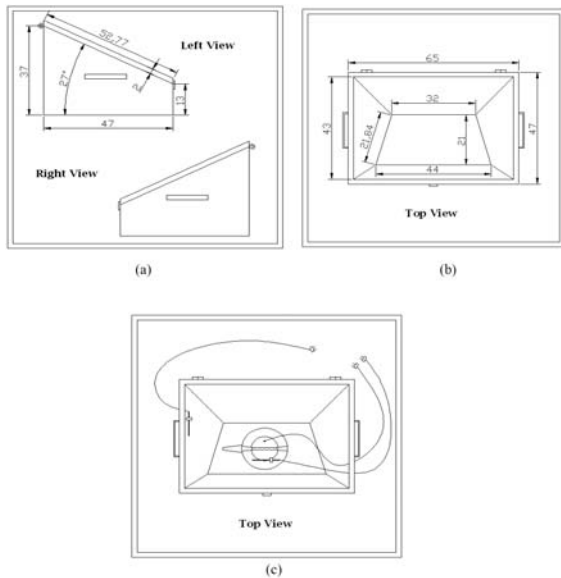

Figure 2 Three dimensional views of the designed solar cooker, (a) and (b) are cooker dimensions in cm, and (c) thermocouple connections in the cooker

Three thermocouples at different locations were installed on the solar cooker. These locations are: a) Outer glass temperature, b) Metallic pot side temperature, and c) water temperature inside the pot. Also, ambient shaded and un-shaded temperature measurements were taken.

Solar intensity radiation was measured by Kipp and Zonen Pyranometer type (CM5) and fixed at a horizontal position. A Digital multi-meter was used to record the output voltage in mV. The device records the data on an accumulative basis and shows the radiation on an instantaneous basis. The temperature measurements were carried out using K type thermocouple coupled to digital thermometer with range from -50 to 150 °C. The accuracy of this thermometer is in the range of 0.3 °C for the temperature measurements between 1 to 99 °C.

4. Results and Discussion

The total input solar energy $Q_{total} = (\tau\alpha)I_s A_g$ which is equal to the summation of the stored internal energy inside the cooker Q_i and the energy loss from the top side Q_{top} , and the energy loss from both bottom and lateral Q_{bottom} . Well established model which neglects the heat capacity of the pot is presented by Jansen 1985 and Kreith and Kreider 1978. It applies the following expression:

$$Q_{water} = Q_{total} - Q_{losses} = Q_{total} - (Q_{top} + Q_{bottom})$$

$$mc(T' - T_w) / \Delta t = [(\tau\alpha)I_s A_g - U_t A_g (T_g - T_a) - U_b A_{wall} - (T_{wall} - T_a)]$$

In the case of fixed cooker, the $\tau\alpha$ (transmittance – absorptance product) changes at different altitude angle as the sun changes its position hourly. Whereas, in the case of tracking system $\tau\alpha$ is at maximum of 0.9.

The thermal performance of both proposed cookers with internally black coated surface and reflecting mirrors is investigated in this section. The results obtained

are plotted as recorded water and metal temperatures against the operating time for fixed position and on tracking system.

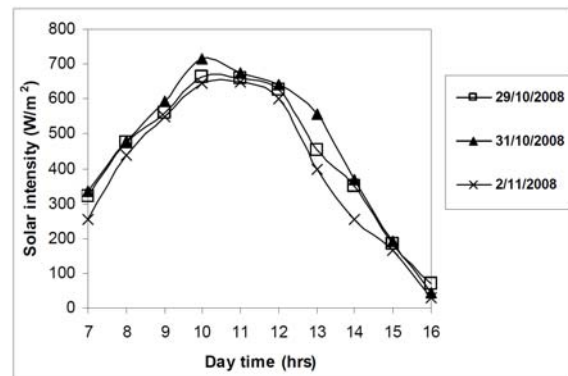

Figure 3 Solar intensities for the three working days

Figure 3 shows the change in the hourly solar intensity for the three working days. It is clear the maximum solar intensity was around mid noon (10:00-12:00 pm).

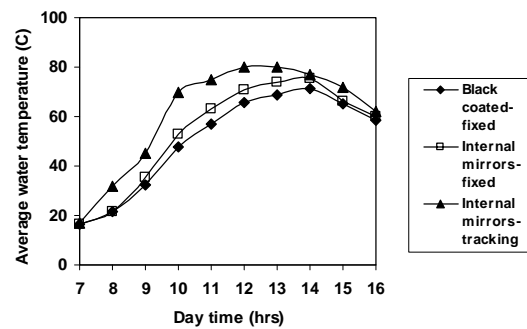

Figure 4 Average water temperature for the three proposed systems at the three working days.

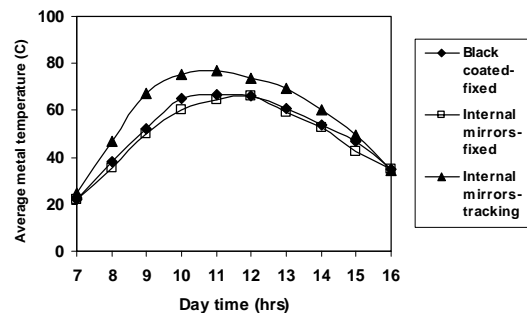

Figure 5 Average metal temperature for the three proposed systems at the three working days

Figures 4 and 5 show the recorded water and metal temperatures through typical summer days (29/10, 31/10, 2/11/2008) from 7:00 am to 16:00 pm. Experiments were carried out for three working days to validate the results obtained. The Figures show an increase in water and metal temperature during early hours of the day until it reaches the maximum temperature around mid noon corresponding to the highest solar radiation then decreases as the sunsets. It is clear that cookers at fixed position with either black coated surface

or internal reflecting mirrors gave close water and metal temperature readings. Whereas, cookers installed on a tracking system gave higher temperature readings and this is expected due to maintaining maximum solar energy entering the cooker system. It was noticed that the maximum water temperatures were recorded around 13:00 – 14:00 pm. Whereas, the maximum metal temperature were recorded around 11:00 – 12:00 am. This is logic where the metal of pot will heat up first then the inside water.

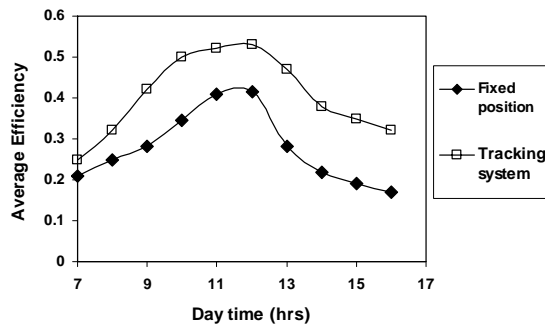

Figure 6 Average efficiency for cookers at fixed and on tracking systems for the three working days

Figure 6 illustrates that cookers at a fixed position had recorded thermal efficiencies ranging from 17 % to a sharp peak of 41.2% at the maximum solar intensity of the day around 11-12 am with an average overall efficiency around 27.6%. Whereas, cooker with internal reflecting mirrors installed on a sun tracking system gave higher water and pot temperatures, and thermal efficiency ranged from 25.3% to 53.1% with an average overall efficiency around 40.6 %. Cookers installed on sun tracking system had the advantage of maintaining a higher and closer range of thermal efficiencies through the daylight than the ones at fixed positions.

5 Conclusion

After conducting statistical analysis on the data obtained from the cookers, It is clear that both types of cookers (black coated and internal reflecting mirrors) at fixed position gave similar thermal performance where the averaged water and pot temperatures were close within $\pm 7\%$ margin of error. The cookers thermal efficiencies at a fixed position ranges from 12 % to an increasing sharp peak of 41.2% at the maximum solar intensity of the day around 11-12 am with an average overall efficiency around 27.6%. Whereas, cooker with internal reflecting mirrors installed on a sun tracking system gave higher water and pot temperatures, and thermal efficiency ranged from 25.3% to 53.1% with an average overall efficiency around 40.6 %. Cookers installed on sun tracking system had the advantage of maintaining a higher and closer range of thermal efficiencies through the daylight than the ones at fixed positions.

References:

[1] M. Telkes, "Solar cooking ovens". Solar Energy Vol. 3, 1958, 1-11.

[2] H. Burkhardt, "Solar cooking: the dormant giant in appropriate technology". Report 39, Ryerson Energy Centre, Toronto, 1982.

[3] A.W.G. Cope and N. Tully, 1981, "Considerations on the development of an urban solar cooker", South African Mechanical Engineer, Vol. 31, No. 9, 1981, 226-234.

[4] K. S. Malhotra, N.M. Nahar, B.V.R. Rao, "An improved solar cooker". International Journal Of Energy Research, Vol. 6, No. 3, 1982, 227-231.

[5] J.D. Walton, "Development of a solar cooker using the spiral Fresnel concentrator". Appropriate Technology, Vol. 10, No. 2, 1983, 27-29.

[6] V. John et.al., "A solar cooker for the common Man". Research And Industry, Vol. 30, No. 1, 1985, 1-5.

[7] G.N. Tiwari, Y.P. Yadav, "A New Solar Cooker Design". Energy Conversion and Management Vol. 26, No. 1, 1986, 41-42.

[8] A.M.A. Khalifa, M.M.A. Taha, M. Akyurt, "Design, simulation, and testing of a new concentrating type solar cooker". Solar Energy Vol. 38, No. 2, 1987, 79-88.

[9] P.C. Pande and K.P. Thanvi, "Design and development of a solar cooker for maximum energy capture in stationary mode". Energy Conversion and Management, Vol. 27, No. 1, 1987, 117-120.

[10] M. Grupp, P. Montagne, M. Wackernagel, "A novel advanced box-type solar cooker". Solar Energy, Vol. 47, No. 2, 1991, 107-113.

[11] Garg H.P and Thanvi, K.P., 1976, Design and performance studies on simple hot box type solar cooker. Res. Ind. 21, 186-187.

[12] Garg, H.P., Mann H.S. and Thanvi, K.P., 1978, Performance evaluation of five solar cookers. Sun : Mankind's Future Source of Energy, Vol. 3, pp. 1491-1496. Pergamon Press, Oxford.

[13] M.M. Hoda, Solar cookers, ISES-U.K. Conference, London, 1977.

[14] M.G. Osman, "Solar energy for cooking in Egypt". Solar Energy: International Progress Vol. 4, 1980, 1768-1795.

[15] V.M. Shrestha, "Modification of the solar cooker". Solar Wind Technol. Vol. 4, 1987, 305-311.

[16] N.M. Nahar, "Performance and testing of a low cost solar water heater cum solar cooker". Solar Wind Technol. Vol. 5, 1988, 611-615.

[17] K.D Mannan et al., "Thermal performance and cooking evaluation of compound cone solar ovens". Proc. Solar Energy Soc. Indian National Solar Energy Convention, Bangalore, 1982

[18] A. Whillier, "A stove for boiling foods using solar energy". Sun at Work Vol. 10, 1965, 9-12.

[19] T.E. Bowman, 1979, "Solar cookers: test results and new designs". Simp. Int. de Ing., San Salvador, 1979.

[20] A. Khalifa, M. Taha, and M. Akyurt, "An energy thrifty solar cooker, the Mina oven". Solar Wind Technol. 1, 8141, 1984.

[21] N.M. Nahar, "Performance and testing of an improved hot box solar cooker". Energy Conversion and Management Vol. 30, No.1, 1990, 9-16.

[22] S.C. Mullick, T.C. Kandpal, S. Kumar, 1991, "Thermal test procedure for a paraboloid concentrator solar cooker". Solar Energy, Vol. 46, No. 3, 1991, 139-144.

[23] S. John, et.al., "Studies on a new combined concentrating oven type solar cooker". Energy Conversion and Management, Vol. 32, No. 6, 1991, 537-541.

- [24] N.M Nahar, J.P. Gupta, P. Sharma, "Performance and testing of an improved community size solar cooker". *Energy Conversion and Management*, Vol. 34, No. 4, 1993, 327-333.
- [25] R.S. Mishra and S.P.S.J. Prakash, "Evaluation of solar cooker thermal performance using different insulating materials". *International Journal of Energy Research*, Vol. 8, No. 4, 1984, 393-396.
- [26] N.M. Nahar, R.H. Marshall, B.J. Brinkworth, "Studies on a hot box solar cooker with transparent insulation materials". *Energy Conversion and Management*, Vol. 35, No. 9, 1994, 787-791.
- [27] A.H. Algifri, H.A. Al-Towaie, "Efficient orientation impacts of box-type solar cooker on the cooker performance". *Solar Energy*, Vol. 70, No. 2, 2001, 165-170.
- [28] S. Kumar, "Estimation of design parameters for thermal performance evaluation of box-type solar cooker". *Renewable Energy*, Vol. 30, No. 7, 2005, 1117-1126.
- [29] S.M.A. Ibrahim, M.K. Elreidy, "The performance of a solar cooker in Egypt". *Energy Sources*, Vol. 15, No. 3, 1993, 415-431.
- [30] S.M.A. Ibrahim, M.K. Elreidy, "The performance of a solar cooker in Egypt, Renewable Energy", Vol. 6, No. 8, 1995, 1041-1050.
- [31] A.Q. Malik, H. Binhusen, "Development of a solar cooker in Brunei Darussalam". *Renewable Energy*, Vol. 7, No. 4, 1996, 419-425.
- [32] G. Oturanc, N. Ozbalta, A. Gungor, "Performance analysis of a solar cooker in Turkey". *International Journal of Energy Research*, Vol. 26, No. 2, 2002, 105-111.
- [33] H. Kurt, "Experimental investigation of thermal performance of hot box type solar cooker". *Journal of the Energy Institute*, Vol. 79, No. 2, 2006, 120-124.
- [34] H.P. Garg, B. Bandyopadhyay, G. Datta, "Mathematical-modeling of the performance of a solar cooker". *Applied Energy*, Vol. 14, No.3, 1983, 233-239.
- [35] J.S. Vaishya et.al., "A hot box solar cooker - performance analysis and testing". *Energy Conversion and Management*, Vol. 25, No. 3, 1985, 373-379.
- [36] B.A. Jubran, M.A. Alsaad, "Parametric study of a box-type solar cooker". *Energy Conversion and Management*, Vol. 32, No. 3, 1991, 223-234.
- [37] T.C.T. Das, S. Karamakar, D.P. Rao, "Solar box-cooker, 1. Modeling". *Solar energy*, Vol. 52, No. 3, 1994, 265-272.
- [38] T.C.T. Das, S. Karamakar, D.P. Rao, "Solar box-cooker, 2. Analysis and simulation". *Solar Energy*, Vol. 52, No. 3, 1994, 273-282.
- [39] A.K. Binark, N. Turkmen, "Modelling of a hot box solar cooker". *Energy Conversion and Management*, Vol. 37, No. 3, 1996, 303-310.
- [40] P.A. Funk, D.L. Larson, "Parametric model of solar cooker performance". *Solar Energy*, Vol. 62, No. 1, 1998, 63-68.
- [41] A.A. Elsebaei, "Thermal performance of a box-type solar cooker with outer-inner reflectors", *Energy*, Vol. 22, No. 10, 1997, 969-978.
- [42] M. Ozkaymak, "Theoretical and experimental investigation of a hot box-type solar cooker performance". *Journal of Power and Energy*, Vol. 221, 2007, 91-97.
- [43] Y.P. Yadav, G.N. Tiwari, "Transient analytical study of box-type solar cooker". *Energy Conversion and Management*, Vol. 27, No. 2, 1987, 121-125.
- [44] A.A. Elsebaei, R. Domanski, M. Jaworski, "Experimental and theoretical investigation of a box-type solar cooker with multistep inner reflectors". *Energy*, Vol. 19, No. 10, 1994, 1011-1021.
- [45] A.A. Elsebaei, S. Aboulenein, "A box-type solar cooker with one-step outer reflector". *Energy*, Vol. 22, No. 5, 1997, 515-524.
- [46] N.M. Nahar, "Design, development and testing of a novel non-tracking solar cooker". *International Journal of Energy Research*, Vol. 22, No. 13, 1998, 1191-1198.
- [47] N.M. Nahar, "Design, development and testing of a double reflector hot box solar cooker with a transparent insulation material". *Renewable Energy*, Vol. 23, No. 2, 2001, 167-179.
- [48] Jansen TJ. *Solar engineering technology*. Englewood Cliffs, NJ: Prentics Hall; 1985.
- [49] Kreith F and Kreider JF. *Principles of solar engineering*. New York: McGrawHill; 1978.

Nomenclature

T' : The temperature after a certain time (one hour in the conducted experiments)

T_w : Water temperature

T_{wall} : Water temperature

T_g : Glass temperature

mc : Water heat capacity (kJ K⁻¹)

$\tau\alpha$:The transmittance – absorptance product

A_g : The glass area (m²)

U_t : The top loss coefficient (w m⁻² K⁻¹)

T_a : The ambient temperature (K)

U_b : The bottom and lateral loss coefficient (w m⁻² K⁻¹)

A_w : The insulated wall area (m²)

I_s : Values were measured

